

OE-XBFXESXXX-X Series

Rev. A

Extraordinary Low Phase Noise TCXO in Europack

Description: The OE-XBFXESXXX-X Series of temperature compensated crystal oscillators (TCXO), provides High Frequency with excellent temperature stability, extremely low phase noise and Low G-sensitivity in Europack.

Features

- Extraordinary Low Phase Noise
- Excellent Frequency Stability
- Low G sensitivity
- No Multiplication – no sub-harmonics
- Very Low Power Consumption (compared to OCXO with similar performance) at any temperature
- Immediate Ready

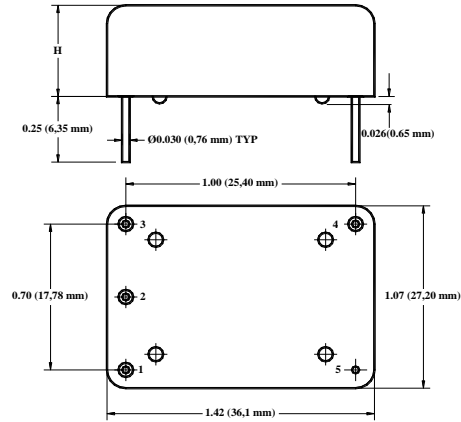

H = 0.75" (19 mm)

Creating a Part Number

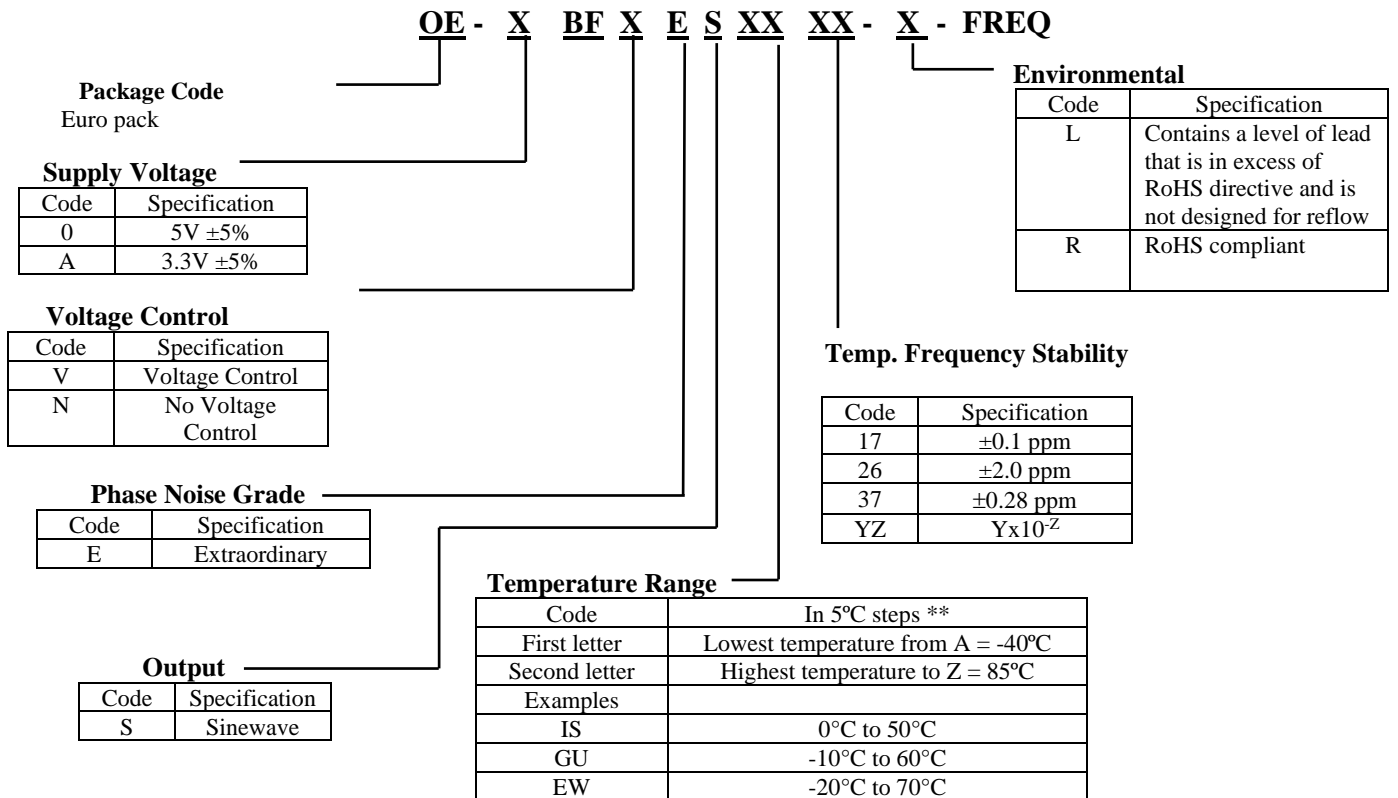

OE-XBFXESXXX-X Series

Rev. A

Note 1) All parameters, unless otherwise specified, are at nominal conditions, ie: T=25°C, Nominal Vcc & Nominal Load

Specifications

Parameter	Symb	Condition	Min	Typ	Max	Unit	Note
<i>Electrical</i>							
Frequency Range	F	Sine-wave	60		125	MHz	
Input Voltage	Vcc		3.2 4.8	3.30 5.0	3.465 5.25	V	A 0
Reference Voltage	Vref	3.3 V Vcc 5.0 V Vcc		2.8 4.5		V	
Power Consumption	Icc	Over all conditions		200		mW	@100MHz
Frequency Stab.	ΔF/F	Overall, available			±4.6		20 years
Frequency Stability	ΔF/F	vs. Temperature vs. Vcc aging		±0.28 ±0.1 ±1 ±2.5 ±3.5		ppm ppm/V ppm/year ppm ppm	See chart First Year 7 years 10 years
G-sensitivity		Worst Axis		0.2		ppb/G	
Calibration	ΔF/F	As shipped, 25°C		±0.5	±1	ppm	
Load		Sine	Internally AC-coupled 50 Ohm				
Output power (output code "S")	P	Sine-wave Into 50 Ohms		15		dBm	
Spurious					-90	dBc	
Harmonics		Sine-wave		-30	-25	dBc	
SSB		@10Hz @100 Hz @1 KHz @10 KHz @100 KHz		-105 -135 -161 -175 -180		dBc/Hz	@100MHz, Grade E
Start-up time				2		seconds	
Input Impedance			>10K Ohm				
Control voltage	Vc		0		3.0	V	
Modulation bandwidth	MB				1.0	Hz	
Deviation	ΔF/F	Vc=0V to 3.3V,25°C	±5	±7		ppm	

Absolute Maximum Ratings

Parameter	Symb	Condition	Min	Typ	Max	Unit	Note
Input Break Down Voltage	Vcc		-0.5		5.5	V	
Storage temp.	Ts		-40		105	°C	
Contr. Voltage	Vc		-1		4	V	

Environmental and Mechanical

Operating temp. range	-40°C to 85°C MAX
Mechanical Shock	Per MIL-STD-202, Method 213, Cond. E
Thermal Shock	Per MIL-STD-883, Method 1011, Cond. A
Vibration	Per MIL-STD-883, Method 2007, Cond. A
Soldering Conditions	260°C for 10s Max leads only
Hermetic Seal	Leak rate less than 1x10 ⁻⁸ atm.cc/s of helium (crystal only)

Electrical Connections

Pin out	Pin #1-Vc ; Pin#2 – Vref ; Pin #3 – Vcc; Pin #4- Output ; Pin #5- GND;
---------	------------------------------------------------------------------------

**Temperature Code Table

Letter	Temp °C	Letter	Temp °C	Letter	Temp °C	Letter	Temp °C	Letter	Temp °C	Letter	Temp °C
A	-40	F	-15	K	10	P	35	U	60	Z	85
B	-35	G	-10	L	15	Q	40	V	65		
C	-30	H	-5	M	20	R	45	W	70		
D	-25	I	0	N	25	S	50	X	75		
E	-20	J	5	O	30	T	55	Y	80		

